



Network of ICT
experienced organisations,
sharing experiences, knowledge
and supporting SMEs
Grant Agreement No.225004



Join The Network

2

➤ Microelectronics

- a. Photonics Electronics Functional Integration on CMOS
- b. Terabit on Chip
- c. SEM-FIB Workbench
- d. Optoelectronic systems for civil security and defense applications
- e. Semiconductor Industry
- f. Bphone
- g. NANOTEC
- h. DS2-Telecommunication
- i. Biological Cell Computation



PROPOSAL/CONTRACT N.: 225004

PROJECT ACRONYM: NET-SHARE

PROJECT FULL TITLE: NETWORK OF ICT EXPERIENCED ORGANIZATIONS, SHARING EXPERIENCES, KNOWLEDGE AND SUPPORTING SME'S.

INSTRUMENT: ICT PSP

DURATION: 36 MONTHS

DISSEMINATION LEVEL: PUBLIC

PROJECT COORDINATOR ORGANISATION NAME: Inovamais, S.A.; www.inovamais.pt

PARTNER NAME: INOVA+

CONTACT PERSON: MIGUEL SOUSA

GOOD PRACTICE NAME: PHOTONICS ELECTRONICS FUNCTIONAL INTEGRATION ON CMOS

SOURCE OF THE GOOD PRACTICE: HELIOS PROJECT [WWW.HELIOS-PROJECT.EU]

TARGET GROUP: SMES

DATE: 15 OCTOBER 2009

HELIOS

p**H**otonics **E**lectronics functional Integration on CMOS

Laurent Fulbert
HELIOS project Coordinator
CEA-LETI, France
www.helios-project.eu

The mission of the large scale integrating project HELIOS is to make CMOS photonics accessible to a broad circle of users. During 4 years, the HELIOS consortium will develop innovative means to combine a photonic layer with a CMOS circuit, using microelectronics fabrication processes.

HELIOS gathers 19 partners among the major European CMOS Photonics and Electronics players and potential users. It will drive the European RTD in CMOS Photonics and pave the way for industrial development.

The project includes the development of such essential building blocks as efficient sources (Silicon-based and heterogeneous integration of III-V on silicon), fast modulators and, beyond, the combination and packaging of these building blocks for the demonstration of complex functions, addressing a variety of industrial needs.

The results of HELIOS will pave the way for applications of CMOS photonics for other fields, eg sensors or optical processing. HELIOS will make integration technologies accessible for a broad circle of users in a foundry-like, fabless way.

About HELIOS:



Basic information about HELIOS

- Large-scale integrating project (IP)
- Start date: 1 May 2008
- Duration: 48 months
- Total budget: 12.048 M€
- Total EC funding: 8.500 M€

It is a project in large-scale, started on the 1st May 2008, with the duration of 48 months, a total budget of 12.048 M€ and with a total EC funding of 8.500 M€.

Rationale of the project

- ◆ Integration of photonics with electronics is needed for improving system **performance** while **reducing size and cost**
- ◆ The key for the success of integration are:
 - Generic wafer-scale integration technologies
 - Small set of elementary components
 - Use of standard design environment and process
 - Technology available through a foundry model → fabless approach

The integration of photonics with electronics is needed for improving system performance while reducing the size and cost. The key for the success of integration are generic wafer-scale integration technologies, a small set of elementary components, the use of standard design environment and processes and a technology available through a foundry model.



Objectives (1)

- ◆ Build a complete **design and fabrication chain** enabling the integration of a **photonic layer** with a **CMOS circuit**, using **microelectronics fabrication processes**.
- ◆ It will make accessible integration technologies for a broad circle of users in a foundry-like, fabless way

The HELIOS objectives are to build a complete design and fabrications chain enabling the integration of a photonic with a CMOS circuit, using microelectronics fabrication processes and make will make it accessible integration technologies for a broad circle of users in a foundry-like.

Objectives (2)

- Development of high performance generic building blocks that can be used for a broad range of applications:
 - WDM sources by III-V/Si heterogeneous integration
 - Fast modulators and detectors,
 - Passive circuits and packaging
- Building and optimization of the whole “food chain” to fabricate complex functional devices.
- Investigation of more promising but challenging alternative approaches for the next generation of devices
- Road mapping, dissemination and training, to strengthen the European research and industry in this field and to raise awareness of new users about the interest of CMOS Photonics.

Others of HELIOS project objectives are the development of high performance generic building blocks that can be used for a broad range of application, to build and optimized the whole food chain to fabricate complex functional devices, to investigate alternative approaches for the next generation of devices and road mapping, dissemination and training, to strengthen the European research and industry in this field and to raise awareness of new users about the interest of CMOS Photonics.

- ◆ High performance building blocks:
 - Integrated III-V/Si laser 3dBm output power, single mode operation, 30dB SMSR, CW laser operation at 65°C
 - 40Gbit/s modulators array with 2 dB active modulation depth, 6dB insertion loss
 - Ge or InGaAs Photodetector BW= 30 GHz, $R>0.8$ A/W, $I_d < 50\text{mA/cm}^2$
- ◆ Alternative approaches:
 - use of silicon related materials as active materials
 - generic architecture (2.5D approach) for the III-V / Si heterogeneous integration of active devices on CMOS

- HELIOS Project challenges:
- High performance building blocks
 - Integrated III-V/Si laser 3dBm output power, single mode operation, 30dB SMSR, CW laser operation at 65°C;
 - 40Gbit/s modulation array with 2 dB active modulation depth., 6dB insertion loss;
 - Ge or InGaAs Photodetector BW=30 GHz. $R>0.8$ A/W, $I_d < 50\text{mA/cm}^2$
 - Alternative approaches
 - Use of silicon related materials as active materials;
 - Generic architecture for the III-V/Si heterogeneous integration of active devices on CMOS.

- Integration of complex phonic function with EIC



Scientific and technological challenges (2)

Integration of complex photonic functions with EIC

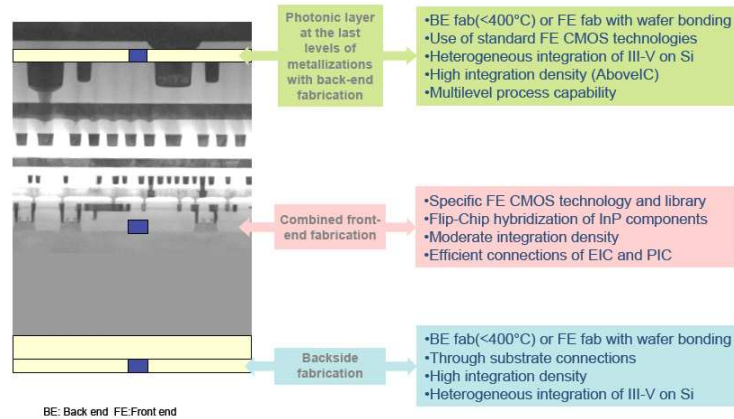

Demonstrators (1)

- ◆ 40Gb/s modulator on a EIC
 - Integration of modulator, monitoring PD and driver
- ◆ 10x10 Gb/s transceiver

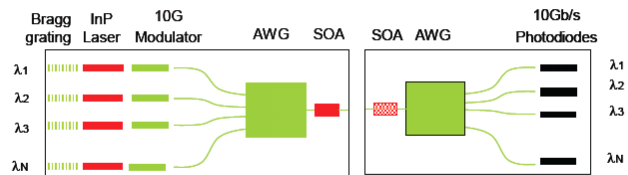

Demonstrators

- 40Gb/s modulator on a EIC
 - Integration of modulator, monitoring PD and driver
- 10 x 10 Gb/s transceiver

Demonstrators (2)

- Mixed analog and digital transceiver module for multifunction antennas

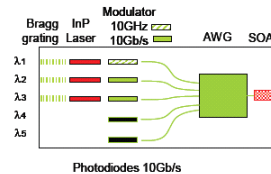

- Photonic QAM-10Gb/s wireless transmission system

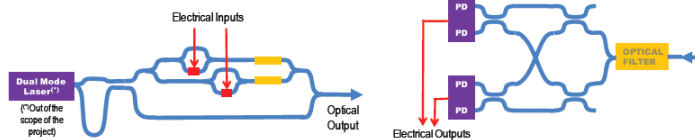

- Mixed analog and digital transceiver module for multifunction antennas

- Photonic QAM-10Gb/s wireless transmission system

Application domains

- ◆ The demonstrators and first applications are in the telecom/datacom field

but ...

- ◆ The results of HELIOS will pave the way for applications of CMOS photonics for other fields, eg sensors, instrumentation, optical processing

Application domains

- the demonstrators and first applications are in the telecom/data field
- the results of HELIOS will pave the way for application of CMOS photonics for other fields, eg sensors, instrumentation, optical processing.



Consortium

- Different but complementary skills are requested to fulfill the project objectives:
 - Industrial end-users to drive the project, define the components architecture and specifications
Photline, DAS Photonics, Thales, (Avanex)
 - III-V industrials to develop III-V on silicon approach, benchmarking
Alcatel Thales III-V lab, 3S Photonics
 - CMOS foundries and design tools experts to ensure technological relevance, photonic/electronic convergence and facilitate further exploitation
AMS, IHP, Phoenix, CNRS, TU Vienna
 - CMOS photonics institutes to develop processes and enable the transfer to foundries
LETI, IMEC
 - Academic laboratories to optimize generic building blocks and develop innovative architectures
CNRS, UNIS, IMM, UPS, UPV, UNITN, UB, TUB

Consortium

- Different but complementary skills are requested to fulfill the project objectives:
 - Industrial end-users to drive the project, define the components, benchmarking;
 - III-V industrials to develop III-V on silicon approach, benchmarking;
 - CMOS foundries and design tools experts to ensure technological relevance, photonic/electronic convergence and facilitate further exploitation
 - CMOS photonics institutes to develop processes and enable the transfer to foundries
 - Academic laboratories to optimize generic building blocks and develop innovative architectures



PROPOSAL/CONTRACT N.: 225004

PROJECT ACRONYM: NET-SHARE

PROJECT FULL TITLE: NETWORK OF ICT EXPERIENCED ORGANIZATIONS, SHARING EXPERIENCES, KNOWLEDGE AND SUPPORTING SME'S.

INSTRUMENT: ICT PSP

DURATION: 36 MONTHS

DISSEMINATION LEVEL: PUBLIC

PROJECT COORDINATOR ORGANISATION NAME: Inovamais, S.A.; www.inovamais.pt

PARTNER NAME: INOVA+

CONTACT PERSON: MIGUEL SOUSA

GOOD PRACTICE NAME: TERABIT-ON- CHIP

SOURCE OF THE GOOD PRACTICE: BOOM PROJECT [[WWW.ITC-BOOM.EU](http://www.ITC-BOOM.EU)]

TARGET GROUP: SMES

DATE:



Micro and Nano-scale silicon photonic integrated components and sub-systems enabling Tb/s-capacity, scalable and fully integrated photonic routers.

Objectives



Worldwide investments (2004...)

- ✓ **“LASOR” (Label Switched Optical Router):**
Co-ordinator UCSB, budget 15,8 M\$
- ✓ **“IRIS” (Integrated Router Interconnected Spectrally):**
Co-ordinator Lucent Technologies budget 12,5 M\$
- ✓ **“Photonic Routing Systems”:**
Co-ordinator UCDAVIS budget 15,8 M\$
- ✓ **“Development of Photonic Network Technology”:**
Co-ordinator NEDO budget 800 Myen

Need to re-enforce European position in photonic routing research

Worldwide investments:

LASOR (Label Switched Optical Router)

IRIS (Integrated Router Interconnected Spectrally)

Photonic Routing Systems

Development of Photonic Network Technology

Problems, problems...

- 
- ✘ Bit rates have been restricted to 40Gb/s
 - ✘ Current λ -converters do not scale
 - ✘ The chip size of AWG circuits could be further reduced
 - ✘ Space switching fabrics (MEMS, PLZTs) exhibit high loss
 - ✘ A photonic integration platform that will enable flexible, functional and cost effective integration is still missing
 - ✘ Cost & space dominated by the use of discrete devices, (single element λ -converters, optical Tx or Rx)

Problems:

- Bit rates have been restricted to 40Gb/s
- Current λ -converters do not scale
- The chip size AWG circuits could be further reduced
- Space switching fabrics exhibit high loss
- A photonic integration platform that will enable flexible, functional and cost effective integration is still missing
- Cost & space dominated by the use of discrete devices.

Concept: multi-material integration on SOI

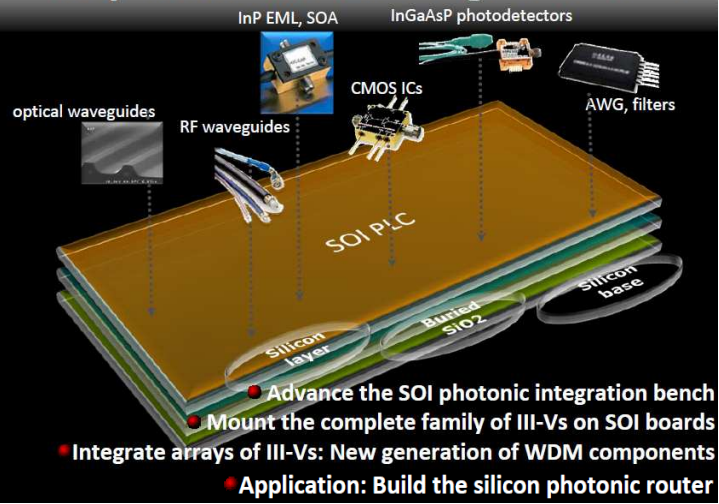

Concept: multi-material integration on SOI

- Advance the SOI photonic integration bench
- Mount the complete family of III-Vs on SOI boards
- Integrate arrays of III-Vs generation of WDM components
- Application: build the silicon photonic router

Scientific & Technology challenges

Cracking the integrated speed limit

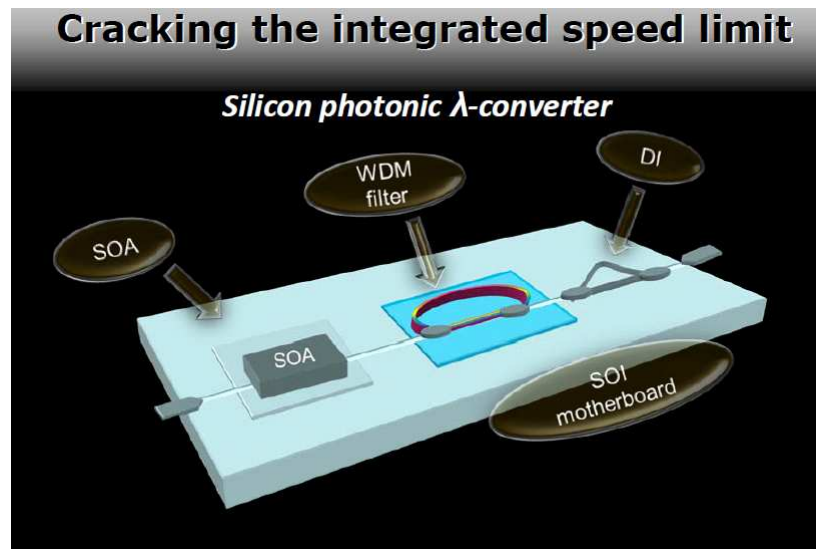

Cracking the integrated speed limit

- Flip-chip bonding of SOA on SOI
- Integration of SOI filters
- 160 Gb/s operation using a single effect element
- ~650mW consumption
- 20x2 mm² chip size

Cracking the integrated speed limit x 4

Arrays of silicon photonic λ -converters

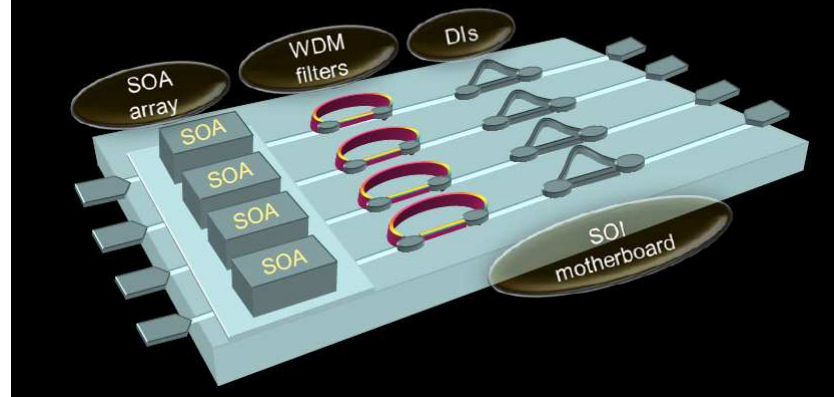

Cracking the integrated speed limit x 4

- Flip-chip bonding of SOA arrays on SOI
- 640 Gb/s (4x160Gb/s) on chip
- <2.5w consumption
- 20x5 mm² chip size

New generation of WDM components

New generation of WDM components

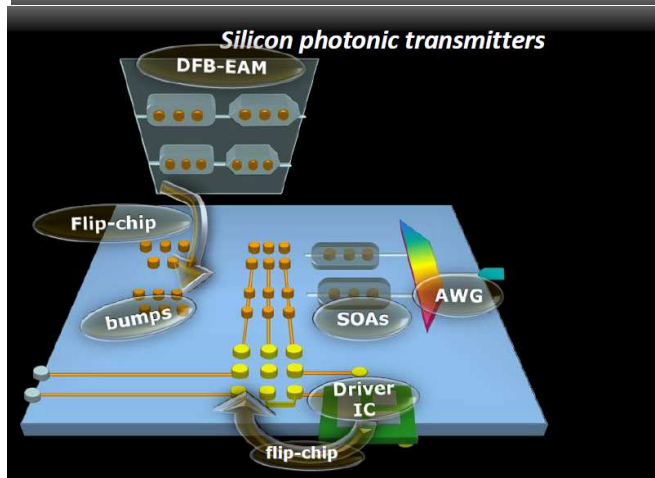

- Flip-chip bonding of EMLs on SOI
- Integration of SOI AWG
- Dual 10Gb/s muxed transmitted
- Electronic drivers on-board.

New generation of WDM components

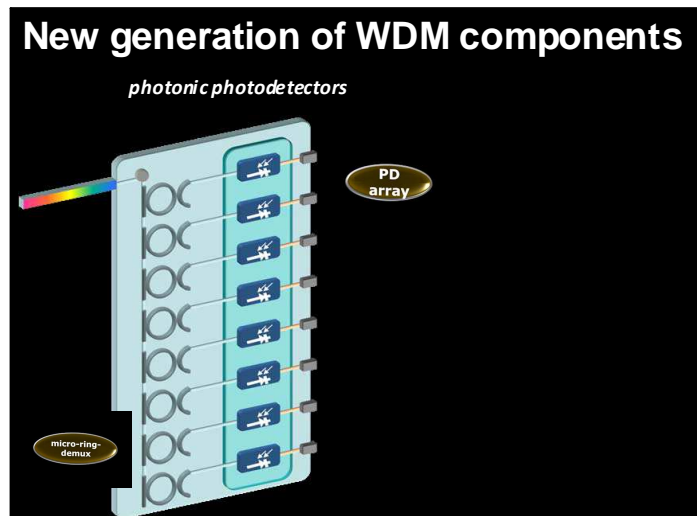

- Die-to-wafer bonding
- 8x 10Gb/s InAlAs-InGaAs PDs on SOI
- micro-ring demux
- 12,5 GHz UDWDM photodetector



Photonic CMOS

Photonic CMOS

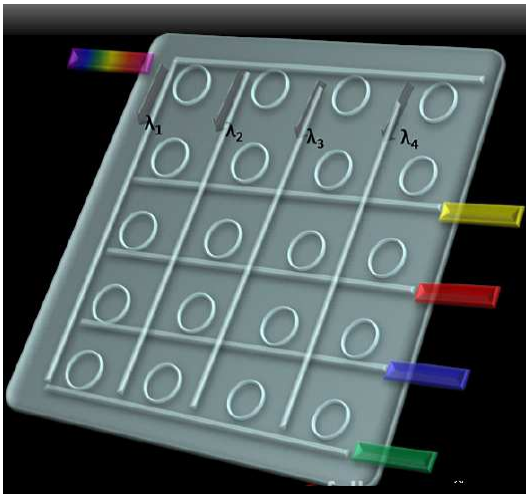

- 2D micro-ring resonator arrays
 - Fully reconfigurable λ -routing cross-connect
 - Low loss waveguides (<0.01 dB/cm)
- Minimum power consumption

System integration

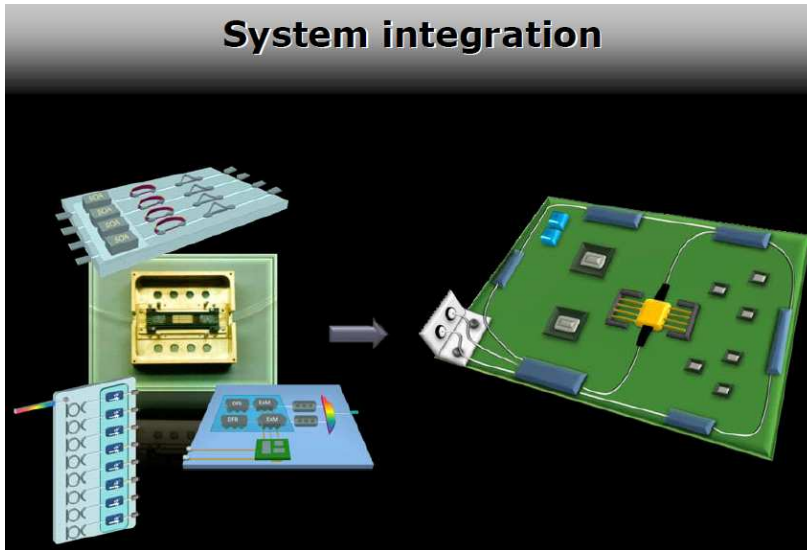

- “optical line cards”
- Integrated photonic λ -routing platform
- Wavelength switching of 160Gb/s channels
- Minimum size & power consumption

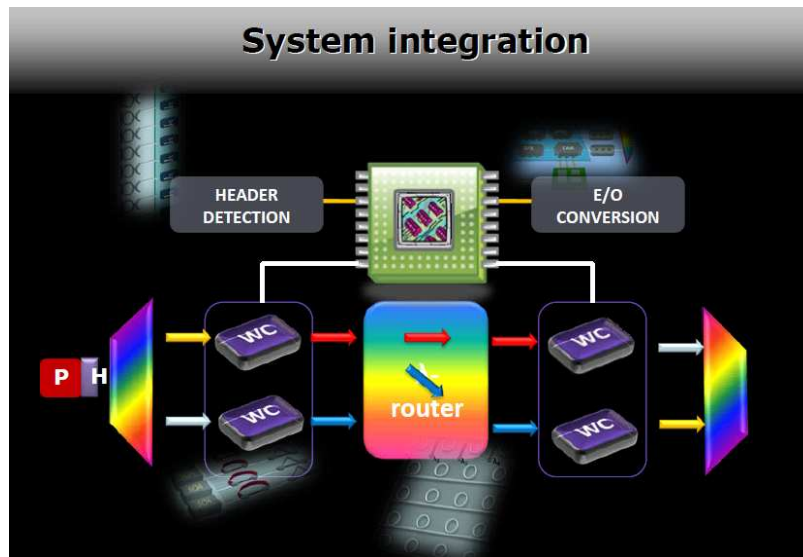

Tested in lab and network operator testbed

Consortium

Consortium Apresentation

BOOM team

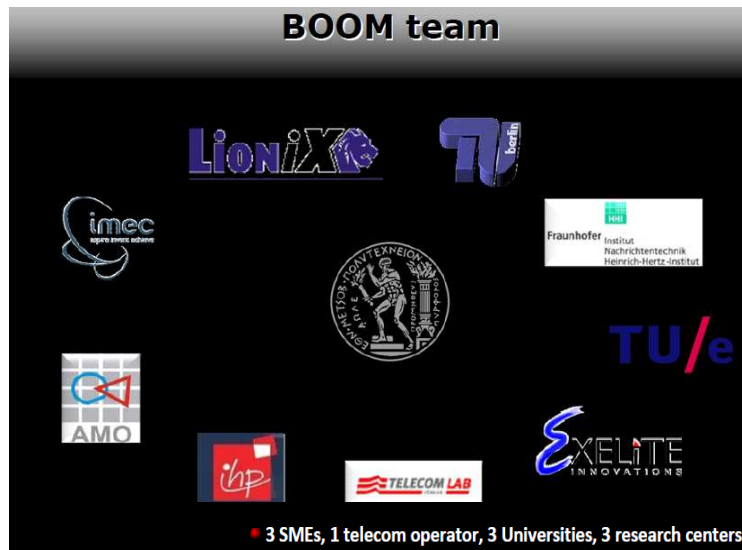

The BOOM team consortium consists of the following members:

- Lionix
- imec
- AMO
- hp
- TELECOM LAB
- Fraunhofer Institut Nachrichtentechnik Heinrich-Hertz-Institut
- TU/e
- EXELITE INNOVATIONS

• 3 SMEs, 1 telecom operator, 3 Universities, 3 research centers

Collaborations



Collaborations:

- III-V silicon heterogeneous integration
- Incorporation of silicon photonic flip-flops in
- The BOOM λ -router
- Demonstration of all-silicon optically controlled

wavelength converters



Acknowledgments



PROPOSAL/CONTRACT N.: 225004

PROJECT ACRONYM: NET-SHARE

PROJECT FULL TITLE: NETWORK OF ICT EXPERIENCED ORGANIZATIONS, SHARING EXPERIENCES, KNOWLEDGE AND SUPPORTING SME'S.

INSTRUMENT: ICT PSP

DURATION: 36 MONTHS

DISSEMINATION LEVEL: PUBLIC

PROJECT COORDINATOR ORGANISATION NAME: Inovamais, S.A.; www.inovamais.pt

PARTNER NAME: FUTURETEC – GESELLSCHAFT FÜR ANGEWANDTE INFORMATIK MBH

CONTACT PERSON: DIPL. INF. WOLF REHM

GOOD PRACTICE NAME: SEM-FIB WORKBENCH

SOURCE OF THE GOOD PRACTICE: KLOCKE NANOTECHNIK (WWW.NANOMOTOR.DE)

TARGET GROUP: SMES

DATE: OCTOBER 2009

Introduction



Do you own ...

- a Material Research SEM?
- a Forensic SEM?
- a Dimensional SEM/FIB?
- an AFM-STM SEM?
- a Tribology SEM?
- a NanoFab in your SEM/FIB?
- a Wafer Probing SEM?
- a Mask Repairing SEM, and much more?

... why not ?

Introduction



A SEM **and/or FIB** can be expanded to a material processing system and an analytical Nano-Workbench by using the only closed loop Nanomanipulators with nm precision available in the market.

The first step

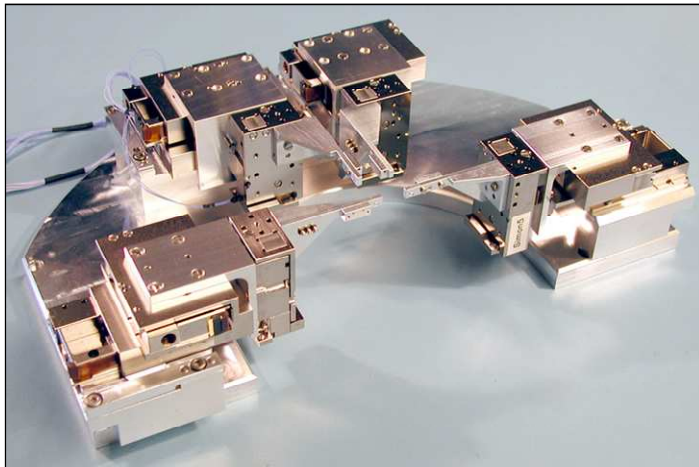

4 absolute positioning Nanorobotics manipulators with
20 x 20 x 10 mm³ stroke at 1 nm resolution

Choose between 1 or up to 6 closed loop Nanorobotics Manipulators from Klocke Nanotechnik, delivered as turnkey solution installed stationary in your SEM/FIB.

The manipulators are equipped with docking stations that allow an easy removal within a few seconds and a cost sparing dual use in air.

The Nanorobotics manipulators are so universal to use, that all following applications can easily be reached by adding further components or modules:

The material research SEM



Various tools for cutting, scraping and manipulation can be added to the manipulators, e.g. for:

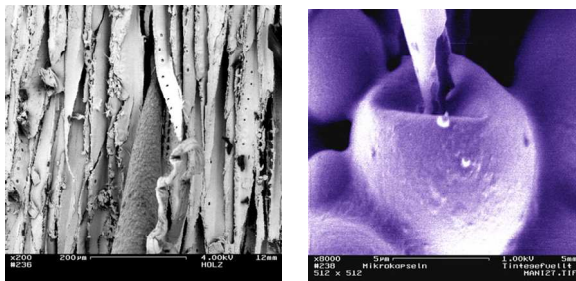

Carbon copy paper industry: A 5 µm diameter ink bubble on carbon paper is touched with the needle, pierced and opened. By touching the individual ink bubble with the manipulators the elastic behavior of the bubbles skin is measured. Since the movement is scaled in nm the wall thickness of the bubble can be determined.

Pharmaceutical industry: For the development of new skin creams the liquidity between individual layers of human skin has to be tested. For this a Nanorobotics manipulator detaches small pieces of frozen human skin layer by layer in the SEM.

Surface coating industry: The adhesion of 300 nm small palladium spheres laminated onto a thick copper film is tested by selectively pushing single spheres with a probe tip until the adhesion breaks. Dependent on the failure mode, the bonding of the spheres is judged: it only fulfills the requirements if the adhesion breaks between the copper and the substrate, not between spheres and copper.

The Forensic SEM, Sherlock Holmes “*in nano*”:

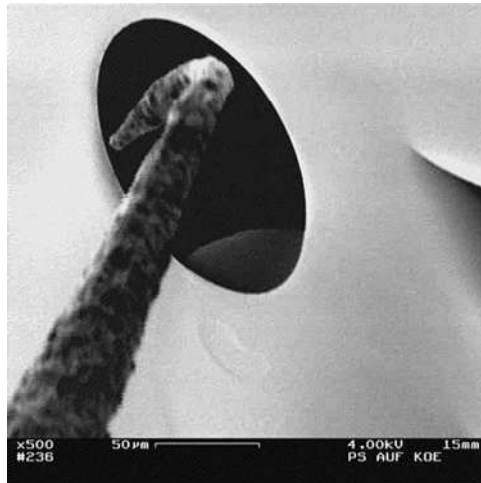

The combination of Nanorobotics manipulators with a SEM allows trace analysis on a previously unknown level. A public example is the determination whether an undamaged car lamp was glowing during a crash, or not. If the lamp is hot (by glowing), small melting points will occur between the windings of the filament, touching each other due to the high acceleration of the crash. To see those melting points, the filament has to be stretched with two micro-hooks, moved by manipulators.

And: Forensic research gets dimensional with the Dimensional SEM!

The Dimensional SEM

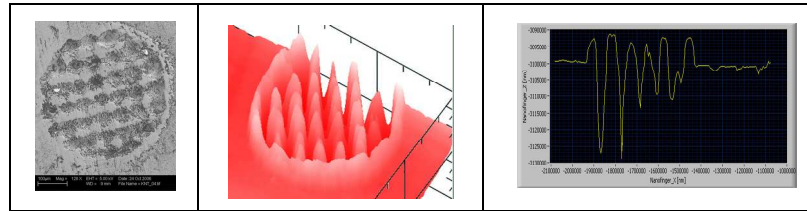

SEM image of a wet clutch, 3 dimensional dataset of the 3D-Nanofinger and a Linescan through an area

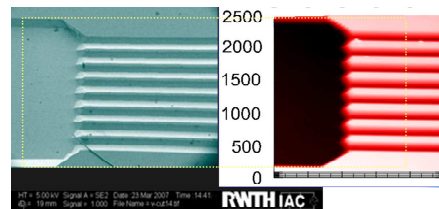

SEM image of V-grooves and quantitative 3D dataset of the same area

Add our 3D-Nanofinger to a Nanorobotics manipulator in a SEM to measure the dimensions of structures. The 3D-Nanofinger combines profilometer and 3D coordinate measuring machine features in a unique way. The metrology features of a SEM are expanded to the third dimension by measuring points, linescans, scans along a 3 dimensional path (inner and outer contours), or by measuring complete 3D surface topographies.

The AFM-STM SEM:

Even a complete AFM or STM scanner head can be fixed as endeffector at the Nanorobotics manipulator in a SEM and moved from its parking position onto those sample areas that were previously identified in the SEM image.

The Tribology SEM

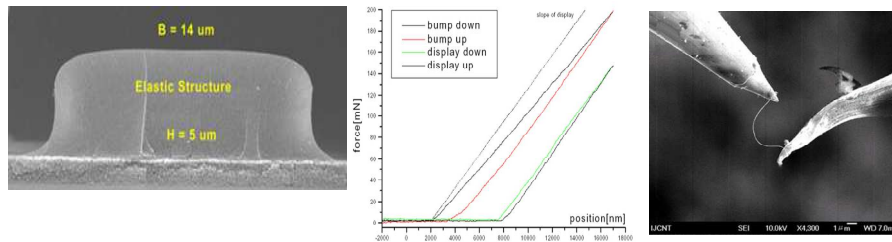

Measurement of Force-Distance curves on elastic microstructures or by pulling at single Carbon Nanotubes

The Tribology SEM:

Micro-Tribology is a wide and important field for future production technology. In-SEM measurements are realized for example as:

- *Stress tests* (movement of elastic micro structures, current or heat stress e.g. at CNTs, ...)
- *Elasticity* (force-distance diagrams of microstructures, bending of nanowires, ...)
- *Reliability* (bond strain tester, e.g. pulling forces of nanowires)
- *Friction* (sticking of micro/nano-objects, ...)

X-Ray Imaging in a SEM

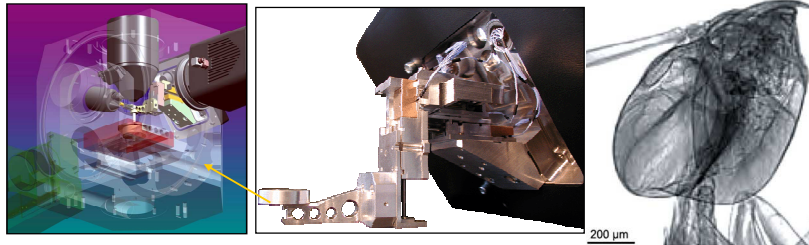

SEM chamber design, Advanced Target Positioner, image of the head of an ant

The X-ray ultraMicroscope from XRT Ltd. (sold by GATAN Inc.) provides X-ray images in absorption and phase contrast, to reveal fine internal structures and edge details. The “Advanced Target Positioner” realized by a Nanorobotics Manipulator is part of the projection X-ray system. It has to keep the target position stable within a few nm over several hours.

The SEM-FIB Workbench



Automatic microassembly of smallest components is a key technology. Production of Carbon Nanotube transistors, AFM tips sharpened by CNTs, or the production of GHz antennas are a few examples. Klocke Nanotechnik is embedded with the “NanoFab” in a network of partners working in this field.

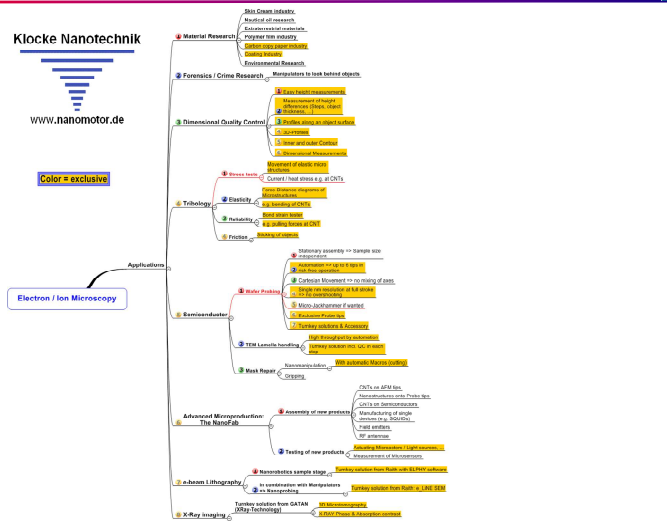

The SEM-FIB Workbench



The high throughput **handling of TEM lamellae** for semiconductor analysis is another important example for using Nanorobotics in automation.

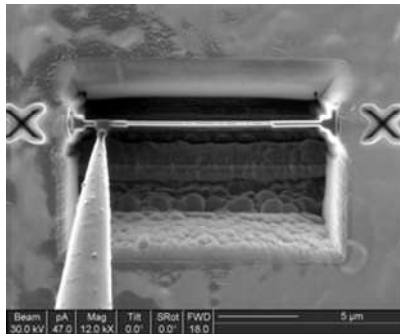

Automatic Sequence:

- FIB moves lamella by pattern recognition into the center of the image. The lamella is already cut at its bottom, but not at both side walls;
- Tip is moved automatically in XY with the Nanorobotics manipulator e.g. beneath the left marker;
- Tip moves down with “Automatic Tip Approach” module with 1 nm increments in closed loop until a certain contact signal is reached;
- Tip is moved up e.g. 1 micron and moved in XY towards the lamella;
- Tip is moved down 1.2 microns to hover beneath the lamella;
- Closed loop tip movement from the side against the lamella;
- Connection of tip with lamella by MOCVD metal deposition;
- The FIB cuts the lamella on both side walls;
- The manipulator moves the lamella automatically to a target position.

The SEM-FIB Workbench



The Wafer Probing SEM:

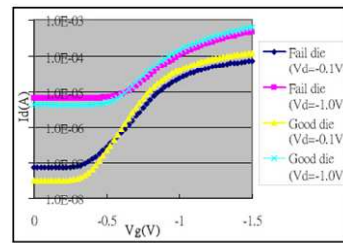
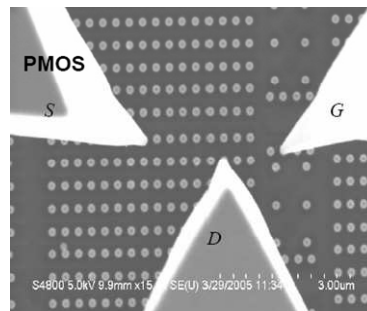

Figure 2 Device behavior is different between the PMOS transistors of bad and good dice. The device of bad die has higher I_{off} .

Only a closed loop Nanorobotics system can move with 3 or more probe tips easily into a diameter of about 100 nm – with 1 nm resolution. Nano-probing allows the characterization of single devices and failure analysis. This work is described in a paper from TSMC (Taiwan), available on request.

The Mask Repairing SEM/FIB:

Mask repairing or e.g. reverse engineering in chip design is as important for the Semiconductor industry as Wafer Probing. Automatic in-SEM/FIB Nanorobotics combines visualization with Nanomachining and particle removal.

The SEM-FIB Workbench



Field Emission in a SEM.

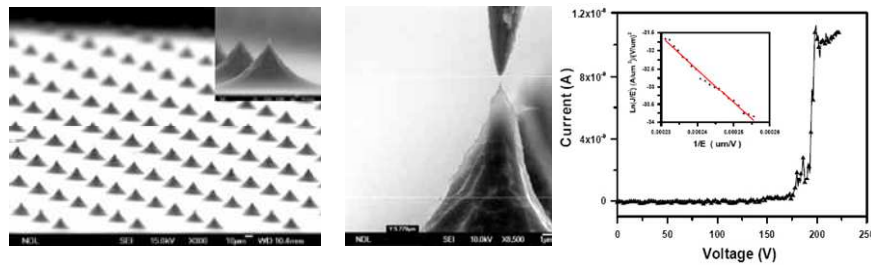

Measurement of field emission properties of Si-emitter by Nanomanipulation in a SEM. This work is described in a paper from NDL (Taiwan), available on request. The diagram shows the field emission behaviour of a single emitter for a 46 nm distance between emitter and sharp anode:

The SEM-FIB Workbench



The Lithography SEM

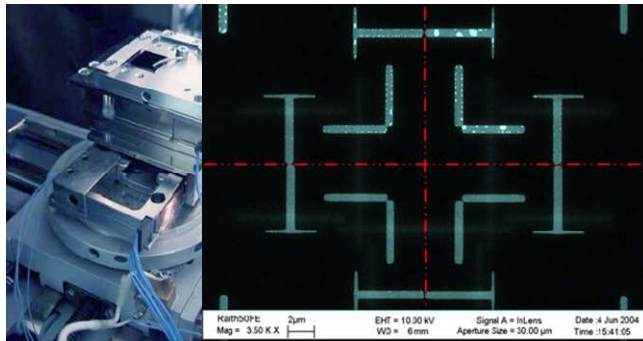

XY-positioning and stitching improvements for conventional SEM based lithography solutions are realized by a Nanorobotics sub-stage assembly, provided as OEM product by Raith, Germany.

4 exposure fields with stitched patterns prove sub micron stitching accuracy. The red dotted line in the upper image indicates the exposure field boundary. This work is described in a paper by Raith, available on request.

The closed loop SEM/FIB sample stage:

The XY-stage described for lithography applications can be expanded to 5 D.O.F. in movement by absolute positioning Nanorobotics modules, e.g. as highest resolution replacement of a manual stage.

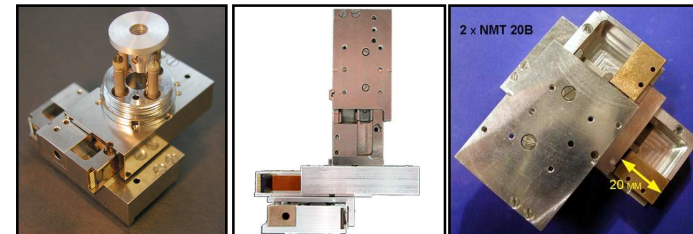

X, Y, Z, Rotation and Tilt movements can be realized in closed loop

The SEM-FIB Workbench



Are you working in the field of ...

- Material Research
- Forensics / Crime research
- Dimensional Quality Control
- High Resolution Analysis
- Tribology
- in-SEM Nanofabrication
- Semiconductor development and production?

***... how can you operate effectively without
Nanorobotics in your SEM?***





PROPOSAL/CONTRACT N.: 225004

PROJECT ACRONYM: NET-SHARE

PROJECT FULL TITLE: NETWORK OF ICT EXPERIENCED ORGANIZATIONS, SHARING EXPERIENCES, KNOWLEDGE AND SUPPORTING SME'S.

INSTRUMENT: ICT PSP

DURATION: 36 MONTHS

DISSEMINATION LEVEL: PUBLIC

PROJECT COORDINATOR ORGANISATION NAME: Inovamais, S.A.; www.inovamais.pt

PARTNER NAME: ARC FUND

CONTACT PERSON: DENITSA MARINOVA

GOOD PRACTICE NAME: OPTOELECTRONIC SYSTEMS FOR CIVIL SECURITY AND DEFENSE APPLICATIONS

SOURCE OF THE GOOD PRACTICE: OPTIX CO. BULGARIA

TARGET GROUP: SMES

DATE: JULY 2009

NET-SHARE Good Practice

Optoelectronic systems for civil security and defense
applications

Optix Co.
Bulgaria

Company's General Information

- OPTIX Co. – a contemporary enterprise with a completely closed production cycle
- Founded in 1998 as a 100% private firm
- World reputation in optomechanical and optoelectronic systems for civil security and defense applications
- Located on 8000 sq. m facilities in the town of Panagyurishte, Bulgaria
- More than 360 qualified employees
- Affiliated companies and representative offices established in Germany, Austria, Switzerland, Scandinavia, UK, Israel, USA.

OPTIX Co. is a contemporary enterprise with a completely closed production cycle.

Founded in 1998 as a 100% private company, it quickly became one of the world leaders in designing, manufacturing and testing of quality optical components and assemblies, opto-mechanical and opto-electronic systems for civil and defense applications.

The company's corporate headquarters are located on 8000 sq. m facilities in the town of Panagyurishte, South-Central region of Bulgaria.

The company has more than 360 employees - graduated specialists and technicians experienced in optical design and production.

Based on its cutting-edge technologies and updated optical and mechanical design software, OPTIX Co. is able to complete the whole production cycle- from the development stage and prototype manufacturing to serial production of parts, assemblies and devices.

OPTIX Co. has established affiliated companies and representative offices in the most competitive markets of Germany, Austria, Switzerland, USA, Israel, UK and the Scandinavian countries.

Quality Standards



- One of the first companies in Europe with a completely 5-level Integrated Management System
 - ISO 9001:2000- Quality control management
 - ISO 27001:2005- Information security management
 - ISO 14001:2004- Environment management
 - NATO AQAP 2110 - Quality control management for the specialized production in the field of defense and security
 - OHSAS 18001:1999- Health and labor safety management
- 90% of the production is exported to the Alliance members.

OPTIX Co. is one of the first companies in Europe with a completely five-level Integrated Management System which includes the following standards:

ISO 9001:2000- Quality control management

ISO 27001:2005- Information security management

ISO 14001:2004- Environment management

NATO AQAP 2110 - Quality control management for the specialized production in the field of defense and security

OHSAS 18001:1999- Health and labor safety management

The high-quality products completely conform to the requirements of the European and World standards - DIN, MIL, ISO, BS.

OPTIX Co. is awarded with the manufacturer/supplier NCAGE code 0001BU as per the NATO codification system. 90% of the entire production of the company is exported to the Alliance members.

Major advantages generated by the standards' adoption are the staff discipline and the set up of production frames that ensure high quality. These are the key prerequisites to the successful participation in international fairs, tenders and partnerships.

Product List



- All products and technologies are designed within the company's R&D unit
- Product list:
 - ✓ Night and day vision equipment
 - ✓ TV systems for day/night surveillance
 - ✓ Mobile thermovision systems for border control and surveillance
 - ✓ Laser range finding systems
 - ✓ In and outside security and alert systems of strategic sites' approaches
 - ✓ Ophthalmologic equipment
 - ✓ Special measurement and test equipment

One of the main advantages of the OPTIX company is that all of its products and technologies are designed and developed within the company's R & D unit.

Based on its capacity in optical design, manufacture and assembly of opto-electronic units the company has successfully developed a wide range of products:

- ✓ Night vision goggles and binoculars;
- ✓ Night and day sights for small arms;
- ✓ TV systems for day/night surveillance;
- ✓ Mobile thermovision systems for border control and surveillance;
- ✓ Laser range finding systems;
- ✓ In and outside security and alert systems of strategic sites' approaches; systems for perimeter and outside perimeter guarding and beforehand warning of the approaches to objects for strategic purposes;
- ✓ Lenses for LCD projection systems;
- ✓ Ophthalmologic equipment;
- ✓ Special measurement and test equipment.

The company has an integrated CAD/CAM system and a complete ERP system for management of all operational levels- production, deliveries, sales, finance and accounting.

Complex security systems



OPTIX has developed and currently produces various technical means for the security guarding of sites of all-national importance. They are a complicated set of day and night observation devices, cameras, signalisation units and information registry structures. All these systems ensure a round-the-clock observation process and the fastest possible discovery, localisation and identification of external objects or accidents. A project of this type was developed and realised by OPTIX for the needs of the Permanent Radioactive Waste Material Depot of the Bulgarian Academy of Science. The systems work in a passive (stand-by) mode and upon activation of the in-built laser source they can be used in conditions of pitch-dark environment.

The above-described complex systems integrate the following subsystems: system for perimeter safe-guarding; system for external (out of the perimeter) safe-guarding and a system for safe-guarding and early warning when the observed objects come closer to the guarded site - main and secondary roads (tracks, accessible locations and others, leading to the site).

The early-warning system is based on inductive and seismic sensors, located at points, perpendicular to the safe-guarded main and secondary access roads. They are connected to an audio and visual signalisation system, located in the guard's observation post, where all the elements, included in the complex safe-guard system, are visualised.

To achieve this goal, the company has developed a combined

Complex security systems



day and night time TV camera "DNK" with an in-built laser illuminator, operating on a wave length of 830 nm (invisible to the human eye). It is delivered in two modifications - "DNK-14" and "DNK-40" respectively with 14 and 40 degrees viewfinder scope, permitting a TV observation of the perimeter and the area between two fences. Each observation post covers between 50 and 120 meters, depending on the specifics of the terrain.

In the year 2000, the OPTIX company developed the complex product, named "System for borderline observation" - ("SBO"), which was purchased for exploitation by the National Service of the Border Police, thus replacing the morally and materially outdated technical equipment used to guard the mainland and marine borders of the Republic of Bulgaria. The "SBO" is a mobile system, developed for day and nighttime observations of the border areas with the help of TV cameras.

OPTIX also offers day and night observation ZOOM cameras. Their major advantage is that they change the field of view and the magnification. These cameras are used for encountering (low magnification - large view field) and identification (large magnification - small view field), of objects moving at high speeds.

Mobile Thermovision Surveillance System "TERMA" for boarder security



The mobile system "[TERMA](#)" is developed for perimeter surveillance, target detection and transmission of collected data to command-control centers via communication means. The vehicle is equipped with suite of sensor and detection technologies and can operate in day/night conditions. The mobile surveillance system enables variable surveillance sequences which are unpredictable for illegal border crossers and invaders.

The system performs the following major tasks:

- Hidden day and night surveillance for detection of intruders over border area, crimes and other offensive activities;
- Measurement of distances up to 20 km to the target;
- Documentation of the observed data by video recording;
- Coordination of capture operations.

Thermovision sight OTS-50 for night surveillance



The thermovision sight "OTS-50" provides surveillance or accurate targeting in total darkness, fog and dust without need of additional IR illuminators (passive mode).

The thermovision sight design enables it to be used as hand-held camera. FPA detector is Uncooled Amorphous Silicon Microbolometer working in spectral range 7-14 microns. With its unique construction the thermovision sight is compact, ergonomic and reliable. The sight is made from high strength aluminium alloy, coated with non – reflective black matte. It ensures its robustness and work in extremely severe environmental conditions. The operation is through menu based push-button GUI. The sight can be connected to an external display through a standard video out to provide remote observation. OTS-50 is supplied with a Picatini Rail Adaptor.

Company's strategy



- **The OPTIX strategy features:**

- ✓ Clearly identified specific market niche
- ✓ Closed production cycle ensuring flexibility and independence from suppliers and subcontractors
- ✓ Significant share of generated income is re-invested in infrastructure and human potential development
- ✓ High quality production of single, small to average sized optical and opto-electronic elements, units and hubs as well as products of high quality according to world standards
- ✓ Deliveries of whole sets of the specially ordered equipment
- ✓ Shorter delivery terms

OPTIX follows an adopted company strategy, which has been motivated by a clearly identified market niche. This specific market space has been won over on the basis of a well-developed and currently functioning customer network, which the company will continue to work on and expand in the coming years.

The OPTIX strategy features:

- ✓ Closed production cycle ensuring flexibility and independence from suppliers and subcontractors
- ✓ Significant share of generated income is re-invested in infrastructure and human potential development
- ✓ High quality production of single, small to average sized optical and opto-electronic elements, units and hubs as well as products of high quality according to world standards
- ✓ Deliveries of whole sets of the specially ordered equipment
- ✓ Shorter delivery terms.

Taking in consideration that the achievement and maintenance of high quality standards has no alternative in the conditions of fierce competition, OPTIX acknowledges the role of the following actions as success factors:

- ✓ Implementation of high quality standards
- ✓ Constant improvement in the existing technologies and implementation of new high-tech achievements

- ✓ Expansion of the technological potential of the company and increasing the share of assembly-related activities
- ✓ A constant improvement of the professional competence of the personnel at all levels
- ✓ Improvements in the measuring devices, laboratory equipment and their capacity.

Coping with the world financial crisis



- **The OPTIX anti-crisis strategy features:**

- ✓ Constant diversification of the products assortment and markets
- ✓ Targeting traditionally stable market niches such as medicine equipment, security and defense
- ✓ Total presence on the market – participation in all major international fairs and forums

By the beginning of the world financial crisis the company's management has succeeded to diversify the products assortment and the markets. The efforts are oriented towards traditionally stable market niches such as medicine equipment, security and defense. One of the main strategic approaches of OPTIX is the total presence on the market through active participation in all major international fairs and forums. As a result the company exports products to 21 countries in all 5 continents.

Main national and international Awards



- Japanese Quality Award “Bosei” - October 2008 - assessment of the Total Quality management Practices
- National contest “Innovative enterprise of the Year”- three successive nominations for the period 2006-2008

In October 2008, OPTIX Co. became one of the first Bulgarian companies to win the Japanese Quality Award “Bosei”. Announced for the first time in Bulgaria the award was initiated by the Bulgarian Chamber of Commerce and Industry, the Bulgarian-Japanese Economic Council, the Institute for Postgraduate Studies at the University of National and World Economy, the Japanese Association for International Cooperation “JICA” and Tokio University. Special commission audited and assessed the effectiveness of the Total Quality Management practices implemented at OPTIX Co. The successful combination of the Integrated Management System (includes 5 international standards) with the Japanese TQM practices was recognized by the jury. The history of the TQM practices at OPTIX began back in 2003 when the company together with the Japanese Productivity Center started a series of in-company trainings and practical tuitions on “Productivity Improvements”, implementing some “Kaizen” activities such as “5S”. Two years later, using the Japanese model for Total Quality Management, the company implemented “Quality Control Circles” that aimed to train and help employees to solve the daily faced problems and analyze their causes. Only three years later the results were visible – the two-way communication between the management and the employees was enhanced and quality of the production was improved.

OPTIX Co was three times nominated for the national contest “Innovative

Enterprise of the Year” in the period 2006-2008. It took second and third places in strong competition with Bulgarian innovative companies from all industrial sectors. The award is given to Bulgarian companies that develop innovative products or processes and have gained steady economic effect by their exploitation. The awarded companies are defined after a peer evaluation of the technical quality of the proposed innovations, their production volumes, companies’ development strategies and policy for protection of intellectual property, investments in R&D processes, quality of the companies’ management.

Employees encouragement programme



- Own educational and training center for new staff members
- Individual qualification plan for each staff member
- Fellowships for education and professional training of staff members in leading universities in Sweden, Germany and UK
- Implementation of “Quality Control Circles” following the Japanese Model for Total Quality Management
- Introduction of “Health” bonus

The company has own educational and training center where newly recruited employees are trained in real conditions to work under the quality standards requirements. Each staff member is trained according to individual qualification plan. Constructors and designers are trained in Sweden and UK. OPTIX company provides fellowships to Bulgarian students in optics for their education at Goettingen University and sponsors the remote education of around 30 of its workers. Following the Japanese model for Total Quality Management, the company implements “Quality Control Circles” that aimed to train and help employees to solve their daily problems and analyze their causes.

OPTIX managers have also introduced the so called “Health” bonus that encourages the sport activities of the employees. The company provides additional payment bonuses to non-smoking and healthy staff members thus reducing the hospitalisations by 30 %.

The company’s recent success has been based on employing a young (average age 32) qualified and enthusiastic team. Enterprise Resource Planning (ERP) is now being introduced to accommodate the additional challenges that are ahead.

Social responsibility



- Donation programme in support of the municipality's cultural activities and infrastructural projects
- Support to local main educational centers – Institute of Optics, High School, Training center for unemployed people

OPTIX Co. plays a significant role in the local community's life. The company has an annual donation programme in support of the municipality's sport and cultural activities, infrastructural projects and public events.

The company also supports the local Institute of Optics, the local High School and the Training center for unemployed people. It offers attractive job opportunities for young people in the area of high technologies by keeping them in the local community and reducing the brain-drain processes.

Contacts



- **OPTIX Co.**
Zahari Stoyanov Str., 65
4500 Panagyurishte
E-mail: optix@optixco.com
Phone +359 357 6 41 25
Fax +359 357 6 3097
URL: <http://www.optixco.com>
- **Subsidiary Companies for:**
Germany, Austria and Switzerland
USA, Israel, Scandinavia
United Kingdom



PROPOSAL/CONTRACT N.: 225004

PROJECT ACRONYM: NET-SHARE

PROJECT FULL TITLE: NETWORK OF ICT EXPERIENCED ORGANIZATIONS, SHARING EXPERIENCES, KNOWLEDGE AND SUPPORTING SME'S.

INSTRUMENT: ICT PSP

DURATION: 36 MONTHS

DISSEMINATION LEVEL: PUBLIC

PROJECT COORDINATOR ORGANISATION NAME: Inovamais, S.A.; www.inovamais.pt

PARTNER NAME: INMARK

CONTACT PERSON: YOLANDA URSA

GOOD PRACTICE NAME: SIDSA ([HTTP://WWW. SIDSA.COM](http://www.SIDSA.COM))

SOURCE OF THE GOOD PRACTICE: SIDSA COMPANY

TARGET GROUP: TELECOMMUNICATION INDUSTRY

DATE: 25 NOVEMBER 2009

Who is SIDSA



Founded in 1992 as a local design center ASICs (Custom Integrated Circuits), **SIDSA is an audiovisual technology provider** with activity areas in semiconductors, conditional access, digital headends and overall project management.

With headquarters in Madrid (Spain), SIDSA began its commercial expansion worldwide, with offices in Dubai, Hong Kong, Moscow and San Francisco.

Nowadays SIDSA is one of the leading technology providers in the Digital Video Broadcast arena, providing as well business solutions and turnkey projects.

SIDSA Feature Products



SIDSA offers several products for the telecommunications market such as:

Digital TV Platforms: for Contribution and Distribution, Chassis and Platforms, DVB-IP Gateways, Encoder and Decoders, Management, Modulators, Monitoring products, Multiplexers and Encapsulators.

KeyFly CAS (Conditional Access Technology): SIDSA's Conditional Access technology for digital satellite, cable and terrestrial TV. It supports all typical pay-TV business models, depending on third party business platform, but has its strongest point in the maximum security level it provides, even against card-sharing.

CAS Devices: A family of products targeted to enable highly secure means to introduce Conditional Access into STBs and iDTV. Some devices are Common Interface CAM: advanced PCMCIA CAM, K1 chipset and CAMwatch controller.

DVB-H mobile TV: Enter e1 is SIDSA's first own commercial DVB-H mobile TV demodulator chipset, that may reach unprecedented Doppler performance and sensitivity even in the most restrictive conditions, the most important aspects in DVB-H reception.

SIDSA Solutions and benefits

Semiconductor Industry

SIDSA is the leading provider of **DVB-H Intellectual Property (IP)** for Integrated Circuits.

SIDSA's DVB-H IP is currently the **best-in-class regarding performance** (Doppler resilience, sensitivity, ...) and the approach is to add more value to the solution therefore including processing capacity, so the complex parts of the standard, such as handover, can be handled inside the IP.

Besides SIDSA has developed a brand new IP that will include T, H and SH (both profiles).

One of SIDSA featured product is **enter_{e1}** chipset, which is a fully featured DVB-H demodulator and processor chipset with the following specifications:

- ◆ MBRAI compliant, ultra high Doppler resilience (more than 250 Hz in 8K mode), best in class sensitivity, low power consumption (less than 40 mW), Less than 4 ms synchronisation time, support of all main silicon tuners in the market, support of 5/6/7/8 MHz channel bandwidths, multi interface, diversity ready, multi service MPE-FEC processing, internal on-chip 8 Mb dynamic memory and embedded ARM processor, embedded PSI/SI & ESG parsing and program streaming and handover



Corporate & Hospitality

SIDSA has been a pioneer in the development of the IPTV industry. SIDSA has focus its efforts on bringing live TV over IP in a fast and cost effective way. Also, the etherTV platform is the most compact and scalable of the market ring and probably the one with less power consumption.

Basically etherTV gateways live content coming from satellite (DVB-S), digital terrestrial (DVB-T) or digital cable (DVB-C) to Ethernet based IP networks. The perfect complement to the DVB-IP gateways are the MPEG-2 etherTV Karina encoder boards, so local channels (like coming from a DVD) can also be introduced in the local IPTV offer.

etherTV platform for Corporate & Hospitality environments is designed targeting cost-effectiveness while keeping a professional degree of robustness and a very simple installation and maintenance, so live TV and e-learning applications can be quickly deployed.

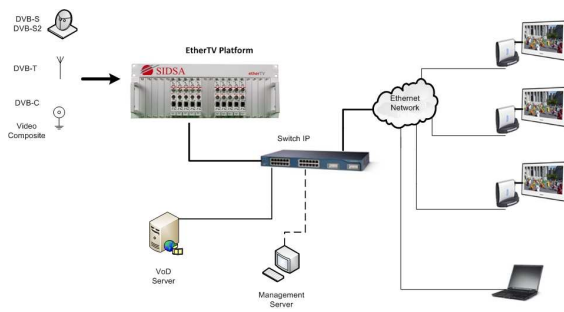

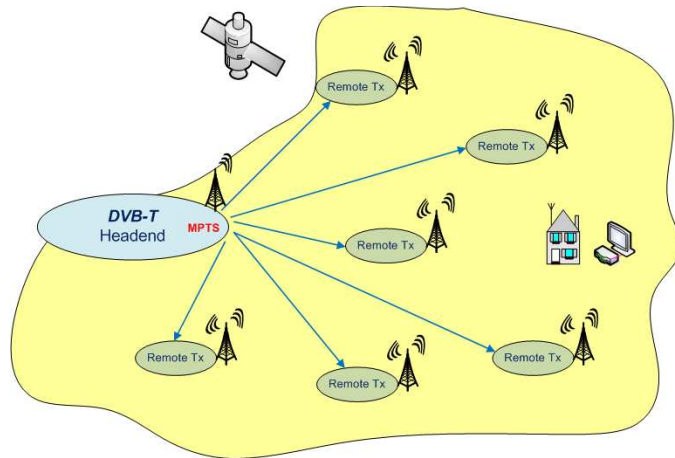

Digital TV

SIDSA is a Company with a deep know-how in all the Digital Broadcast value-chain, from the DVB-T/H standards themselves to the way content should be protected or the different business models that need being supported. **SIDSA** provides different levels of turn-key fully interoperable Digital Broadcast Solutions for broadcasters reducing dramatically time-to-market and enhancing the operator's success probabilities and the value of the overall proposition.

SIDSA and its partners, selected among key vendor leaders, can provide complete solutions, among them: headend (MPEG-2 and H.264 codecs), Conditional Access System, program guide, interactivity, network planning, distribution network, transmitters and gap fillers, or local integration and support.

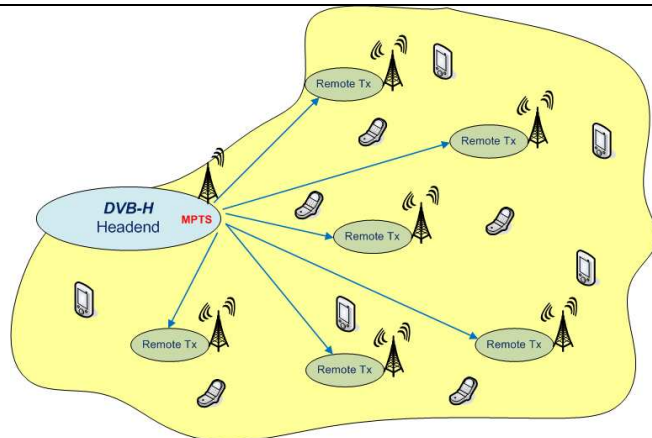

Mobile TV

As DVB-H standard is gaining momentum in the audiovisual arena and Mobile Network Operators start to explore Mobile TV possibilities using DVB-H, the need of a company with a sound expertise gets more and more important.

SIDSA provides different levels of turn-key fully interoperable Digital Broadcast Solutions for content providers, broadcasters and operators to launch cutting edge DVB-H Mobile TV solutions. SIDSA helps operators and broadcasters drive user revenues by creating live TV offers (video on demand, interactive applications, ...) that can be packaged as a bouquet of channels, following a free-to-air or pay-per view model

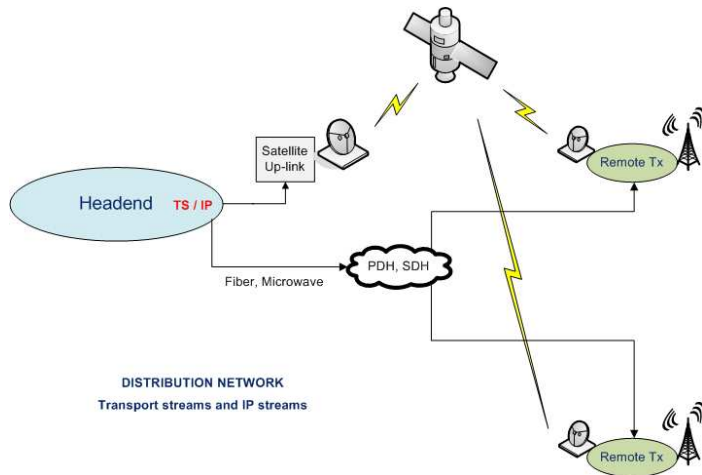

Content Distribution Network (CDN)

SIDSA has developed a cost effective solution for Contribution and Distribution Networks (CDN) via satellite and IP networks: **POLAR CDN**.

Using POLAR CDN, a broadcaster can distribute DVB-T/H transport streams via satellite and terrestrial links directly to transmission sites, **respecting SFN synchronization and securing the content**. This solution also considers the network redundancy scenario.

In the same way a broadcaster can deliver IP streams from a site to other sites using DVB networks, i.e. satellite links, reaching remote sites where IP connection is “fragile”, impossible or very expensive. The contents can be encrypted allowing the restricted access.

The key component in POLAR CDN is the Orion devices: the Orion Encapsulator in the headend and the Orion Receiver at the remote sites.

KeyFly CDN

KeyFly 2.0
Xtreme

Broadcasters

SIDSA has developed a **very advanced new Conditional Access system** that prevents the most typical hacking attack nowadays, card-sharing. And not less important, tremendously reduces the overall cost of the CA system where matters the most, at the receiver side (always keeping security renewable).

SIDSA provides Broadcasters with B2B and B2C Conditional Access technology to protect against unauthorised access to the most valuable asset.

- ◆ The B2B solution for secure encryption of content in Contribution networks is KeyFly CDN, specially optimised to provide the maximum degree of security and performance.
- ◆ SIDSA's technological answer to the increasing demand of higher levels of security and mechanisms to fight against card-sharing is KeyFly 2.0 Xtreme Conditional Access System for Digital Satellite and Terrestrial TV.

enter_{tv}

enter_μ

Mobile TV device manufacturers

SIDSA is the leading provider of DVB-H Intellectual Property (IP) for Integrated Circuits, with customers that include important semiconductor suppliers to the Mobile Industry.

SIDSA understands the issues that DVB-H devices manufacturers (OEM modules, mobile phones, PmP, etc.) need to face, as they are also building networks and services for Operators.

The outcome of years of research and team work with Industry leaders is a family of reference designs and modules for DVB-H reception:

- ◆ For consumer electronic devices manufacturers who want to jump into the DVB-H market with a plug&watch solution (the heavy DVB-H SW stack running inside the enter1 chipset and communicating, with the Host using standard IP protocols over SDIO or USB interfaces), SIDSA offers **entertv**.
- ◆ For Gap Fillers and Domestic Fillers manufacturers that need an OEM DVB-H receiver module that gives professional measurements, for the possibility to build equipment that, knowing the status of the network, may be able to perform automatic stand-alone adaptation. SIDSA provides unique measurement functionalities (recommended at the main fora so the (domestic) gap fillers are always working correctly without oscillation. For these clients, SIDSA developed **enterμ**.



PROPOSAL/CONTRACT N.: 225004

PROJECT ACRONYM: NET-SHARE

PROJECT FULL TITLE: NETWORK OF ICT EXPERIENCED ORGANIZATIONS, SHARING EXPERIENCES, KNOWLEDGE AND SUPPORTING SME'S.

INSTRUMENT: ICT PSP

DURATION: 36 MONTHS

DISSEMINATION LEVEL: PUBLIC

PROJECT COORDINATOR ORGANISATION NAME: Inovamais, S.A.; www.inovamais.pt

PARTNER NAME: VDC

CONTACT PERSON: VITA VITOLA

GOOD PRACTICE NAME: B-PHONE

SOURCE OF THE GOOD PRACTICE: VENTSPILS HIGH TECHNOLOGY PARK

TARGET GROUP: SMS's

DATE: OKTOBER 2009

Grant Agreement: 225984



B-phone

Comfort! Safety! Freedom!



Ltd. B-phone – developer and producer of innovative baby monitoring device.

Grant Agreement: 225884



About the company:

- Located in Riga and Ventspils
- The idea of the B-phone was discovered using traditional baby monitor. These conventional products do not provide all the necessary functions of watching a baby.
- Development of the product took 12 months
- From early 2009 the *B-phone* became the first innovative baby monitoring device to be brought to the market by the company



Company was founded in the city of Ventspils. The company made its first steps in business incubator of Ventspils high technology park. Now it's situated in Riga and Ventspils, where necessary resources are available for the production of electronic products. Development of the product took 12 months, of which 6 months were dedicated to the product testing and configuring of maximum functionality

Grant Agreement: 225984



Company goals

1. To create a positive company image
2. To become in the coming 4 years the one of the European market leaders in the area of baby monitoring system production.
3. To create a united and efficient working team.
4. To form efficient and reliable network of cooperative partners
5. To develop other innovative products in the area of technology



Companies main goals are:

1. To create a positive company image
2. To become in the coming 4 years the one of the European market leaders in the area of baby monitoring system production.
3. To create a united and efficient working team.
4. To form efficient and reliable network of cooperative partners
5. To develop other innovative products in the area of technology

Grant Agreement: 225884



Business profile

- Processing
- Production of computer, electronic and optical devices
- Production of communication devices



Business profile: Processing, Production of computer, electronic and optical devices, production of communication devices.



Most important *B-phone* features (1):

- The baby monitoring device works within the GSM mobile operator network, and can be linked with a land line or mobile phone;
- Detects sound or movement;
- Can notify up to three predefined phone numbers;
- One can easily call the baby monitoring device *B-phone* from it's phone to hear what is happening around it;

The most important features of the device that company want to stress are that baby monitoring device works within the GSM mobile operator network, and can be linked with a land line or mobile phone. Device also detects any sound or movement, that baby makes. Device can notify up to three predefined phone numbers. Parents can easily call the baby monitoring device B-phone from their phone to hear what the baby is doing and what is happening around him or her.

Grant Agreement: 225884



B phone

Most important *B-phone* features (2):

- *B-phone* can be easily attached to a strap or placed on a horizontal surface;
- *B-phone* has an unlimited range.
- The sensitivity of the sound and movement sensors of the *B-phone* can be regulated
- Parents only need a mobile phone with them



As the rest of most important features and competitive advantages company stresses that device can be easily attached to a strap or placed on a horizontal surface. B-phone has an ultimate range – it works wherever one have mobile phone network coverage, mobile phone is the only thing that parents need to have with them to reach the device. The sensitivity of the sound and movement sensors of the B-phone can be regulated.

Grant Agreement: 226884





B phone

Technical information of the *B-phone* (1)

- Size 100x45x25mm;
- Movement and sound sensor sensitivity can be adjusted;
- Microphone and loudspeaker volume can be adjusted;
- Battery life of 48 hours;



netShare



Size of the baby monitoring device is 100X45X25 mm.

Movement and sound sensor sensitivity can be adjusted as well as microphone and loudspeaker volume can be adjusted. Battery hold up to 48 hours.

Grant Agreement: 225884 



B phone

Technical information of the *B-phone* (2)

- The device can be placed at a up to 3 metre distance form the baby;
- A call or SMS notifies about the baby waking up;
- You can easily call the device;
- You can adjust the settings of the device by sending SMS or using the browser in your mobile phone.

Continuing with the technical information – the device can be placed at up to 3 meter radius from the baby. A call or sms notifies specified numbers when the baby is waking up. Parents can easily call the monitoring device, to listen what the baby is doing and what is happening around. Parents can easily adjust setting of the device themselves by sending SMS or using the browser in their mobile phones. The mobile phone must support JAVA database connectivity.

Grant Agreement: 226984



B phone

Target partners

- Company have participated in exhibitions in Latvia and Germany
- Established Contacts with more than 80 providers around the world
- 25 companies have already ordered samples



Company have actively started participating in exhibitions in Latvia and Germany, through the established contacts 25 companies have already ordered samples of the baby monitoring device and others have shown interest in future cooperation. Latvia's biggest children supply stores and internet stores any already providing device to its customers.

Grant Agreement: 225994



B phone

Target countries

- Germany
- USA
- Australia
- Israel
- France
- Denmark
- Netherlands
- UK
- Poland
- Hungary
- Spain
- Republic of South Africa
- Chile
- Bangkok



Company's established contacts are all around the world they are not just concentrating on one region. Potential partners are separate stores, store chains and internet stores in these mentioned countries.

Grant Agreement: 225884 



www.b-phone.eu
SIA "B-phone"
Ropažu st. 140, Rīga, LV-1006
Phone +371 636 29661
Fax: + 371 636 29662
E-mail: info@b-phone.eu



Feel free to contact the company for any further questions.



PROPOSAL/CONTRACT N.: 225004

PROJECT ACRONYM: NET-SHARE

PROJECT FULL TITLE: NETWORK OF ICT EXPERIENCED ORGANIZATIONS, SHARING EXPERIENCES, KNOWLEDGE AND SUPPORTING SME'S.

INSTRUMENT: ICT PSP

DURATION: 36 MONTHS

DISSEMINATION LEVEL: PUBLIC

PROJECT COORDINATOR ORGANISATION NAME: Inovamais, S.A.; www.inovamais.pt

PARTNER NAME: INMARK

CONTACT PERSON: YOLANDA URSA

GOOD PRACTICE NAME: NANOTEC ([HTTP://WWW.NANOTEC.ES](http://www.nanotec.es))

SOURCE OF THE GOOD PRACTICE: NANOTEC COMPANY

TARGET GROUP: RESEARCH COMPANIES AND ORGANISATIONS

DATE: 08 OCTOBER 2009

Who is NANOTEC Electrónica S.L.



Nanotec Electrónica is a Spanish based company that develops Scanning Probe Microscopes (SPM) with the best quality and the latest technology in the field, providing both scientific and industrial communities easy access to the nanometer scale.

Nanotec Electrónica also designs and manufactures control systems for Scanning Probe Microscopes. In the software sector, NANOTEC has developed the free **WSxM software** for data visualization and processing of SPM images, and distribute the SIESTA DFT software for first principle calculations.

Company History

In 1981, Heinrich Rohrer and Gerd Karl Binnig invented the first Scanning Tunneling Microscope (STM) at the IBM Research Center in Zurich. In 1983-84, Professor Arturo Baro from the Universidad Autónoma de Madrid (UAM) spent a sabbatical at IBM Zurich and learned firsthand about the construction and operation of STMs. As a result of this collaboration, H. Rohrer installed the first STM in Spain in 1984. Both Binnig and Rohrer were awarded the Nobel Prize in Physics in 1986 because of this invention. From that moment, Professor Arturo Baro's group in Madrid started working on the development of the Scanning Tunneling Microscope and quickly achieved world-wide reputation in this new research field.

By 1998, the microscopes from Professor Baro's laboratory were very advanced. Since the interest in the field continued to grow at a rapid pace, there were several companies formed to manufacture scanning probe microscopes. Professor Baro's laboratory was also providing UAM scanning probe microscopes for non-profit collaboration with other university groups throughout the world. Because of the high prices that commercial companies were charging for their equipment, the Spanish research community found it difficult to purchase new research-grade SPMs. It was at this moment that Nanotec Electronica was born.

Professor Arturo Baro, together with three researchers from the UAM labs, Jaime Colchero, Julio Gomez and Jose Maria Gomez, started up a new company, Nanotec Electronica, for the manufacture and sale of Scanning Probe Microscopes. Because of the extensive research base at UAM, the young company was manufacturing very competitive AFMs and electronics for STM control from the very beginning. The high quality of this instrumentation resulted in outside recognition and Professor Arturo Baro was awarded the Madrid Research Prize in 1998.

Since 1998, the new Nanotec Electronica company began ambitious projects with the target of obtaining a leading position in the market of Scanning Probe Microscopy. Their investments in research and development combined with high quality products were amplified by innovative collaborations with many research groups world-wide.

Cervantes AFM System features

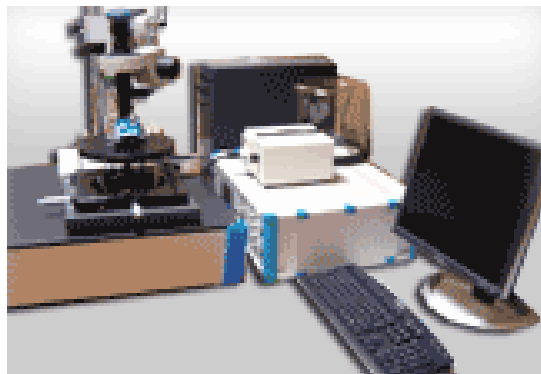

Cervantes AFM System is a tool for characterizing and performing experiments on samples at the nanoscale. It is a modular, open and versatile microscope, designed not only for obtaining the highest quality images, but also for those applications that require a characterization of other physical properties of your sample. The open and accessible design of Cervantes leads to a better understanding of the SPM process and is especially suitable for scientists wishing to get the SPM technique to its limit, as well as for educational purposes. The flexible design of Cervantes implements innovative modifications that allow you to add new features to your existing experiments.

The modular elements of Cervantes are:

- **Dulcinea Electronics:** Its open architecture, flexibility and power is based in the combination of the WSxM software for Real Time Data Acquisition, the M6701 Innovative Integration Digital Signal Processor with 16 analog input and 16 analog output channels and the Nanotec Electronica designed Dulcinea electronics, with optional integrated lock-in module for Dynamic Force measurements.
- **Computer Control System:** State-of-the-art Dell computer, with preinstalled Windows XP Professional and the powerful M6701 DSP, combined with the famous WSxM software. By using Nanotec hardware, all the flexibility inherent in the WSxM software can now be at your fingertips.
- **WSxM Free Software:** WSxM is a powerful and user-friendly Windows application for Data Acquisition and Processing in Scanning Probe Microscopy (SPM).
- **SPM Chassis:** provides the coarse approach, allows environmental control, and the ability to position the SPM head below a high-powered optical microscope. The Chassis has been designed for easy adaptation to any configuration of the system.
- **SPM Scanners:** NANOTEC piezoelectric scanners incorporate a concentric tubular design to minimize thermal drift. The easy exchange of a long and a short scanner allows you the possibility of selecting the one that you prefer for each experiment.
- **SPM Head:** Offers high stability for the most demanding measurements, combined with a simple design that gives easy access for custom modifications or educational purposes, together with a very user friendly operation.

Cervantes AFM System benefits

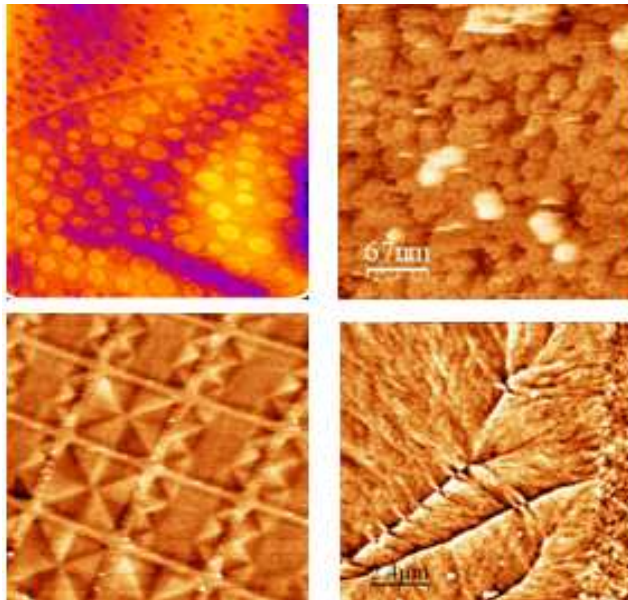

The Cervantes is a stable, robust and versatile AFM that allows the maximum resolution and the widest possible range of experiments.

It has been used in many applications ranging from the study of biologic molecules in a liquid environment, to the study of the magnetic domains in a hard disk, or the measurement of the conductivity of carbon nanotubes.



PROPOSAL/CONTRACT N.: 225004

PROJECT ACRONYM: NET-SHARE

PROJECT FULL TITLE: NETWORK OF ICT EXPERIENCED ORGANIZATIONS, SHARING EXPERIENCES, KNOWLEDGE AND SUPPORTING SME'S.

INSTRUMENT: ICT PSP

DURATION: 36 MONTHS

DISSEMINATION LEVEL: PUBLIC

PROJECT COORDINATOR ORGANISATION NAME: Inovamais, S.A.; www.inovamais.pt

PARTNER NAME: INMARK

CONTACT PERSON: YOLANDA URSA

GOOD PRACTICE NAME: DS2 (HTTP://WWW.DS2.ES)

SOURCE OF THE GOOD PRACTICE: DS2 COMPANY

TARGET GROUP: TELECOMMUNICATION INDUSTRY

DATE: 08 OCTOBER 2009

Who is DS2



Founded in 1998 in Spain, DS2 is the leading technology innovator and a global provider of high speed semiconductor solutions for powerline communications, a technology that converts any installed wire into an intelligent, high speed networking medium. In 2004, DS2 introduced the first 200Mbps Powerline Communication Integrated Circuits.

Mission

DS2 mission is to engage their customers at the vanguard of innovation by creating the most advanced, sustainable and successful powerline, coaxial and phoneline communications technology solutions.

Vision

DS2 vision is to enable everybody to enjoy wireline connectivity.

DS2 Featured Products

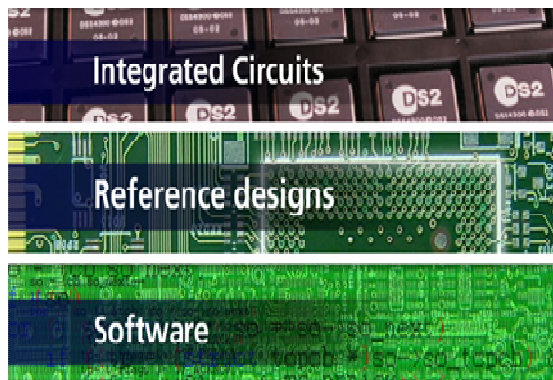

Integrated Circuits (IC)

The DS2 family of digital Integrated Circuits provide maximum integration at a very low cost and is completed by the analog ICs. Advanced OFDM (Orthogonal frequency-division multiplexing) modulation provides the ability to cope with the challenges of any type of medium, be it powerline, coax, twisted pair or any other, and deliver a peak data rate of more than 200Mbps for bandwidth hungry applications

Reference Designs

DS2 has developed a complete set of reference designs for user modems as well as for infrastructure equipment. The designs have been thoroughly validated for Electromagnetic compatibility (EMC) and thermal performance, and can provide an advanced foundation for manufacturers seeking to minimize their time to market.

Software

DS2 has 4 different Software packages. Each packet has been designed to take full advantage of the characteristics and power embedded in the DS2 Integrated Circuits. The individual software packages have been prepared to provide performance and unique features for each application.

DS2 Solutions and benefits

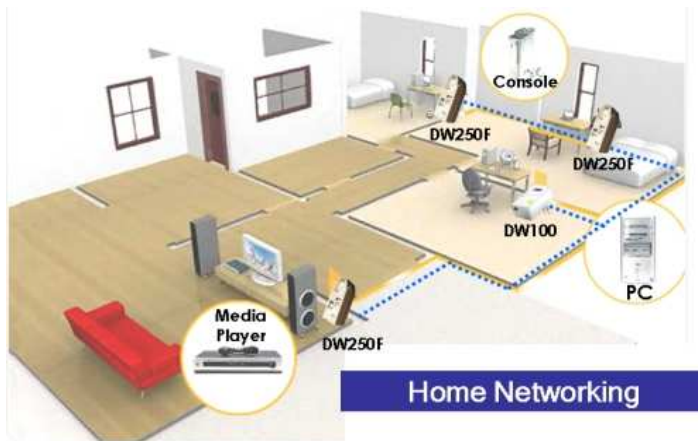

Home Networking

DS2 technology runs on any type of wire present in the home, and unlike wireless solutions, it is not attenuated by walls. The electrical wiring, the coaxial TV cable or the phone-lines of the home can be turned into a high speed network, allowing the user to put a digital device anywhere and easily share information.

Some of the main advantages offered by DS2 Home Networking Technology are Full Home Coverage, Plug-and-Play Installation with push-button configuration, Security through AES Encryption, Advanced Neighbouring Networks, Quality of Service for Multiple Traffic Streams, Graphical network mapping of nodes in Windows Vista and Windows 7 (LLTD), Very low Power Consumption and Stand-by Mode and Full interoperability between all home networking node.

IPTV Distribution: The latest generation high speed anywire communications technology from DS2, conforming to the Universal Powerline Association's "Digital Home Standard", provides instant home networking for operators with fast, simple, secure products that enhance the user friendliness and profitability of IPTV rollouts. The DS2 IPTV solution enables a broadband IPTV connection to be sent anywhere in a home by using the existing electrical wiring or any other cable available such as coax or phone line.

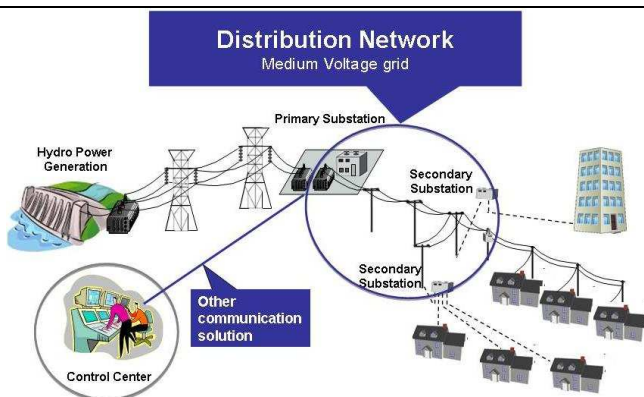

Smart Grid: Distribution Network

The solution designed by DS2 for the Medium Voltage network is called DS2 Distribution Network solution. This solution covers the area from the Primary Substation to the Secondary Substation, providing a real-time 2-way communication network with scalability for new applications and adding new nodes.

The benefits of this solution are: 2-way real-time communication, a fully scalable solution, high bandwidth for future applications, network structure fully configurable through Frequency and Time Division, added value through self-healing mechanisms embedded in the technology, standards based system, TCP/IP as an integrated part of the system and an embedded SNMP client that allows any standard Network Management tools to be used.

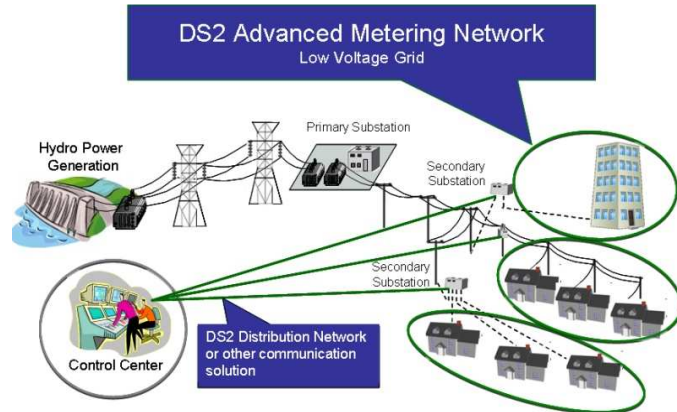

Smart Grid: Advanced Metering

The DS2 Advanced Metering Network solution has been designed to meet all the communication challenges of AMI (Advanced Metering Infrastructure). The solution enables a plug-n-play network in the Low Voltage grid, from the Secondary Substation to the Meter.

Compared to other AMI solutions, such as Wireless, DS2 Advanced Metering has great advantages, like very low cost vs. expensive licensed wireless network, immune and proven technology vs. unlicensed wireless network that receives interference from everywhere, and fully owned and controlled network vs. dependent mobile networks.

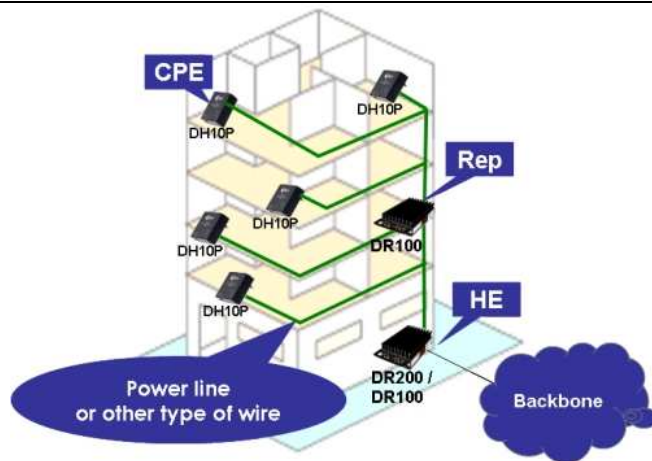

Smart Buildings

System Integrators and administrators of public buildings know that creating a network infrastructure in a multi-dwelling unit or any public or office building is not a straight forward task. Rewiring is intrusive for customers and both costly and time consuming to install. DS2's Smart Building simplifies the installation process significantly by using the existing electrical or coaxial wires, or any other physical medium, to create an instant high-speed communication network.

This solution has the following benefits: DS2 Anywire technology extends any commercial broadband connection (xDSL, cable, BPL, FTTx, WiFi or satellite) over the existing wiring for instant, full connectivity in any type of building. The high performance Smart Building solution can be used within any type of building to support secure, connectivity to high-speed Internet, VoIP, IPTV and other network services and applications.

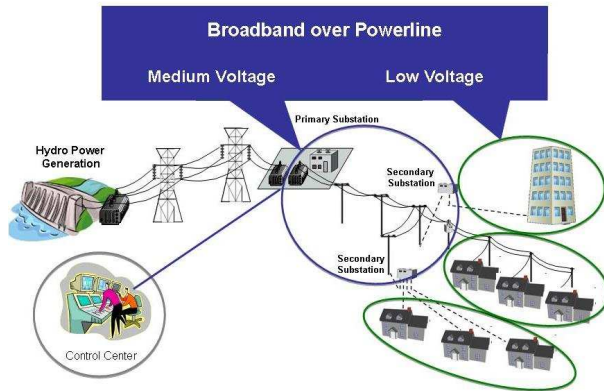

Broadband Powerline

DS2 technology allows any electrical network to be converted into a high-speed access mechanism. DS2 supports powerful repetition capabilities, which allows the PLC signal to reach any corner of the electrical grid, all the way from the primary substation to the home of the end-user.

Last mile access can be provided by using the electrical cabling that connects every building to its transformer substation; it is even possible to fit Medium Voltage Secondary substations with DS2-based equipment, allowing quick and inexpensive deployment of metropolitan area networks using the medium voltage powerlines (10 kVolts to 66 kVolts cables) as a transmission medium.

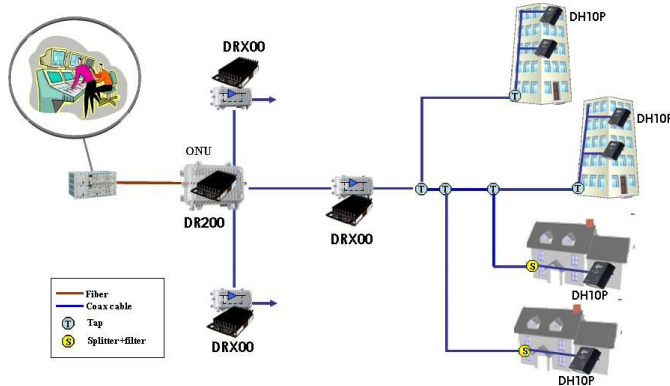

Ethernet over Coax

The coax cable has been installed in great scale worldwide as the medium to transport cable television signals. Alone in the US almost 100% of the housing units have coax networks on their doorstep. As the Internet revolution came along cable operators saw the potential in the coax cable and started to also provide Internet services over the coax cable. However the systems used today to provide Internet over the coax cable requires a significant investment, so operators and equipment manufacturer are looking for a more economical solution.

DS2 Ethernet over Coax solution is based on the DS2 technology that was originally designed for the very harsh and complicated powerline medium. Taking advantage of the robustness of the technology, DS2 has adapted it to the requirements of the coax cable to provide a high performing, secure and feature rich solution at a much lower cost than any other system in the market.



PROPOSAL/CONTRACT N.: 225004

PROJECT ACRONYM: NET-SHARE

PROJECT FULL TITLE: NETWORK OF ICT EXPERIENCED ORGANIZATIONS, SHARING EXPERIENCES, KNOWLEDGE AND SUPPORTING SME'S.

INSTRUMENT: ICT PSP

DURATION: 36 MONTHS

DISSEMINATION LEVEL: PUBLIC

PROJECT COORDINATOR ORGANISATION NAME: Inovamais, S.A.; www.inovamais.pt

PARTNER NAME: WIT

CONTACT PERSON: SINEAD QUEALY

GOOD PRACTICE NAME: Biological Cell Computation supporting protocols for Nano/MEMS - Communication

SOURCE OF THE GOOD PRACTICE: BIOLOGICAL CELL COMPUTATION

TARGET GROUP: Nano and Micro-Electro-Mechanical Systems

DATE: 01/03/10



WIT
Good Practice
for
NetShare

TSSG

Waterford Institute of Technology
INSTITIÚOIC TEICNEOLAÍOICHTHÍR NÓCTA LÁIRGE

Enterprise Ireland

sfi
Science Foundation of Ireland

HEA
Higher Education Authority
An tArd-Chomhairle na n-Éireann

7
SEVENTH FRAMEWORK PROGRAMME

Biological Cell Computation supporting protocols for Nano/MEMS-Communication

Funded by:

- Science Foundation of Ireland (SFI)
- Higher Education Authority (HEA)

End User scenarios

1. To create a software simulation package that can enhance and support novel Biosensor/chip design

Biological Cell Computation supporting protocols for
Nano/MEMS-Communication

Biological Cell Computation supporting protocols for Nano/MEMS-Communication

Frank Walsh
Sasitharan Balasubramaniam (Sasi)
Dmitri Botvich

*Waterford Institute of Technology
Waterford, Ireland*

Introduction

- Nanotechnology are devices on the scale of the order of one billionth of a meter(10^{-9})
- Micro-Electro-Mechanical Systems (MEMS) – integration of sensors, actuators, electronics through microfabrication.
- Tremendous potential to support various fields of science
 - Patient monitoring
 - Drug delivery
 - Sensor Networks
- Operate at a sub-cellular level. Crucial functionality is communication mechanisms between peer Bio-Nano/MEMS devices
 - Limitations due to size addressed through cooperative capabilities between various devices (distributed systems paradigm).
- Problem Statement
 - Creating computation to support communication
 - Power constraints of Bio-Nano/MEMS scale devices deployed in bio-cellular systems
 - Heterogeneity of deployment environments

This research project focuses on combing the Nano devices (machines and instruments not even visible to the naked eye) with MEMS, electrical sensors enabling communication.

There is substantial potential for the application of this research in the medical and communications fields. The enhancement of patient monitoring; more targeted and effective drug delivery; enhanced communication; just a few ways this research can improve our lives in the future.

Some of the problems facing the researchers include the very size of the environment in which they are operating – a sub cellular level, that is, within a biological cell.

Nano devices are incredibly useful, but don't always have room for batteries!

Proposed Solution

- Biological Nano and MEMS communication platform supporting a nano scale communication network.
 - maps concepts from telecommunication and data communication protocols to underlying biological systems.
- Main aim is to create a communication platform that will interface Nano and MEMS biochip devices to biological cells to support communication between peer devices.
- Platform to enable devices to access the cells and perform any necessary logic computation required by the protocol

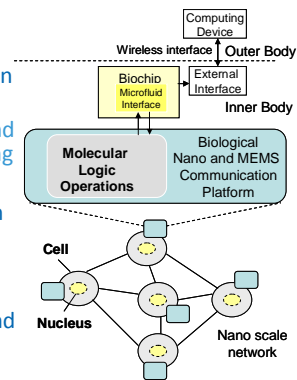

The researchers aim to enable biological cells to support communication between peer devices using telecommunications and data communications protocols.

This work will create a method of not only allowing communication to take place within the body but also to allow nano devices to perform work within a cell based on information is receives through the biological Nano and MEMS communications platform.

Proposed Solution - Mapping of Communication Protocol to Cell Signalling

- Logic circuit to support specific communication protocols (e.g. BTCP: Bio – Transmission Control Protocol; BUDP: Bio – User Datagram Protocol)
- Appropriate signalling mechanism in the cell are selected to perform logic computations
- Logic operations can occur in compartments to support parallel processing

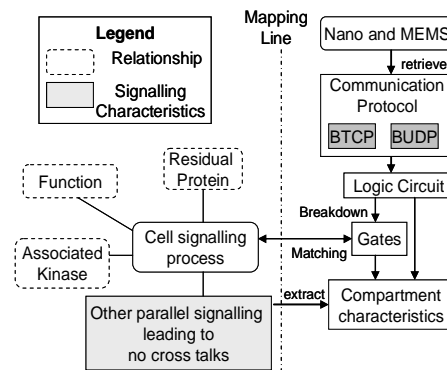

Through predefined logic circuits designed to operate within specific communication protocols, the system can enable sub cellular communication and manipulation.

A device can respond to the signalling mechanism within a cell to perform a logic based function.

Next Step and Research Challenges

- Next step is to create a suite of signalling pathways that can be integrated to support a continual logic circuit function
- Research Challenges to be considered:
 - Expansion of circuit for multi logic function in single pathways
 - Expand to more realistic models, reflecting real world situation and also may lead to this effect
 - Integrate cell noise condition that may affect logic computation stability
 - How do species and concentration heterogeneity affect pathway operation.
 - How can a signalling pathway be 'reset' to initial operating conditions.
 - Integrate inter-cellular propagation condition and technique of interfacing to physical layer propagation (e.g. calcium signalling)
 - What other protocols can be adopted and extended (e.g. Routing protocols)
 - Due to enlargement of circuit size, do we adopt new protocols, or adopt new molecular computation to increase efficiency
 - OR hybrid molecular computation techniques
 - Adopting pure telecommunication protocols may not work. In the same way new routing protocols were adopted for sensor and ad hoc networks – do we need the same for molecular communication.

As with any field of research, once one way is proven to work, it only remains to see how far it can be developed. This is no different in biological cell computation.

Next, the researchers hope to establish circuits of communication and to apply the learning to more realistic and real world requirements.

There will be a need to test thoroughly in a number of environments and across a range of species.

Also to be considered will be the ability to harness the signalling currently taking place in a cell for the purposes of computation and communication. Perhaps a purely telecoms approach may not be sufficient.

Conclusion

- Nano/MEMs devices have plenty of applications in the medical field
- A challenge is to support communication between these devices due to their characteristics (operations and environment)
 - Multi-disciplinary research that is trying to apply communication theory techniques to biological communications
- Presented communication framework that can be used to support communication between devices
 - Cell-signalling pathways mapping to logic gates
 - Integrated signalling pathways to perform logic communication circuits
- Aim is to create a software simulation package that can enhance and support novel Biosensor/chip design
- Research challenges

Conclusion:

This project could be of considerable use in the medical field for diagnosis, assessment of illness and delivery of drugs.

Biological Cell Computation relies on a multi-disciplinary approach across telecommunications and software, to nano device manufacture and molecular research and expertise.

It is hoped that this research will enhance the area of Biosensor and Biochip design.